

TB 9-4920-451-35

CHANGE 1

DEPARTMENT OF THE ARMY TECHNICAL BULLETIN

**CALIBRATION PROCEDURE FOR
FUEL QUANTITY GAGE TEST SET
SIMMONS PRECISION, INC., MODEL 472090-002
GULL AIRBORNE INSTRUMENTS, MODEL GTF-4; AND
CONSOLIDATED AIRBORNE SYSTEMS
MODELS TF20-1 AND TF579**

Headquarters, Department of the Army, Washington, DC
30 November 2006

Distribution Statement A: Approved for public release; distribution is unlimited.

TB 9-4920-451-35, 21 October 2003, is changed as follows:

1. Remove old pages and insert new pages as indicated below. New or changed material is indicated by a vertical bar in the margin of the page.

Remove Pages
7 through 10

Insert Pages
7 through 10

2. File this change sheet in front of the publication for reference purposes.

By Order of the Secretary of the Army:

Official



JOYCE E. MORROW
*Administrative Assistant to the
Secretary of the Army*

0627504

PETER J. SCHOOMAKER
*General, United States Army
Chief of Staff*

Distribution:

To be distributed in accordance with IDN 342054, requirements for calibration procedure
TB 9-4920-451-35.

*TB 9-4920-451-35

DEPARTMENT OF THE ARMY TECHNICAL BULLETIN

CALIBRATION PROCEDURE FOR FUEL QUANTITY GAGE TEST SET SIMMONS PRECISION, INC., MODEL 472090-002 GULL AIRBORNE INSTRUMENTS, MODEL GTF-4; AND CONSOLIDATED AIRBORNE SYSTEMS MODELS TF20-1 AND TF579

Headquarters, Department of the Army, Washington, DC
21 October 2003

Distribution Standard A: Approved for public release; distribution is unlimited

REPORTING OF ERRORS AND RECOMMENDING IMPROVEMENTS

You can improve this manual. If you find any mistakes or if you know of a way to improve these procedures, please let us know. Mail your letter or DA Form 2028 (Recommended Changes to Publications and Blank Forms) directly to: Commander, U.S. Army Aviation and Missile Command, ATTN: AMSAM-MMC-MA-NP, Redstone Arsenal, AL 35898-5000. A reply will be furnished to you. You may also provide DA Form 2028 information to AMCOM via e-mail, fax, or the World Wide Web. Our fax number is DSN 788-6546 or Commercial 256-842-6546. Our e-mail address is: 2028@redstone.army.mil. Instructions for sending an electronic 2028 may be found at the back of this manual. For the World Wide Web, use <https://amcom2028.redstone.army.mil>.

SECTION		Paragraph	Page
	I. IDENTIFICATION AND DESCRIPTION		
	Test instrument identification	1	2
	Forms, records, and reports	2	2
	Calibration description	3	2
	II. EQUIPMENT REQUIREMENTS		
	Equipment required	4	3
	Accessories required	5	3
	III. CALIBRATION PROCESS FOR SIMMONS PRECISION, INC., MODEL 472090-002		
	Preliminary instructions	6	4
	Equipment setup	7	5
	Internal calibration	8	5
	Capacitance measurement calibration	9	8
	Capacitance substitution calibration	10	9
	Resistance measurement calibration	11	10
	Final procedure	12	12

*This bulletin supersedes TB 9-4920-451-35, dated 11 December 1987, including all changes.

	Paragraph	Page
IV. CALIBRATION PROCESS FOR GULL AIRBORNE INSTRUMENTS, MODEL GTF-4		
Preliminary instructions.....	13	12
Equipment setup	14	12
Capacitance.....	15	13
Resistance	16	15
Final procedure.....	17	16
V. CALIBRATION PROCESS FOR CONSOLIDATED AIRBORNE SYSTEMS, MODELS TF20-1 AND TF579		
Preliminary instructions.....	18	16
Equipment setup	19	16
Capacitance.....	20	18
Resistance	21	18
Final procedure.....	22	19

**SECTION I
IDENTIFICATION AND DESCRIPTION**

1. Test Instrument Identification. This bulletin provides instructions for the calibration of Fuel Quantity Gage Test Set, Simmons Precision, Inc., Model 472090-002; Gull Airborne Instruments, Model GTF-4; and Consolidated Airborne Systems, Models TF20-1 and TF579. The manufacturers' manuals were used as the prime data sources in compiling these instructions. The equipment being calibrated will be referred to as the TI (test instrument) throughout this bulletin.

a. Model Variations. Variations among models are described in text.

b. Time and Technique. The time required for this calibration is approximately 4 hours, using the dc and low frequency technique.

2. Forms, Records, and Reports

a. Forms, records, and reports required for calibration personnel at all levels are prescribed by TB 750-25.

b. Adjustments to be reported are designated (R) at the end of the sentence in which they appear. When adjustments are in tables, the (R) follows the designated adjustment. Report only those adjustments made and designated with (R).

3. Calibration Description. TI parameters and performance specifications which pertain to this calibration are listed in table 1.

Table 1. Calibration Description

Test instrument parameters	Performance specifications
Simmons Precision, Inc., Model 472090-002	
Capacitance measurement (external)	Range: 40 to 999.9 pF Accuracy: ±0.5% of reading Range: 1000 to 2000 pF Accuracy: ±.5% of reading
Capacitance substitution (internal)	Range: 40 to 999.9 pF Accuracy: +0.5% of reading Range: 1000 to 2000 pF Accuracy: ±.5% of reading
Resistance	Range: 1.0 to 1000 MΩ Accuracy: +1 increment -.4 increment
Gull Airborne Instruments, Model GTF-4	
Capacitance	Range: 0 to 8000 pF in 4 ranges ¹ Accuracy: ±0.5% of range setting
Resistance	Range: 0 to 100,000 MΩ in 4 ranges Accuracy: 1.0 to 1000 mΩ +.5% of reading 1000 to 10,000 MΩ +10% of reading 10,000 to 100,000 MΩ +15% of reading 0.1 to 1.0 MΩ +1.0% of range
Consolidated Airborne Systems, Models TF20-1 and TF579	
Capacitance	Range: 0 to 5000 pF Accuracy: +0.5% of FS
Resistance	Range: 0 to 10,000 MΩ Accuracy: 10% of reading

¹Verified from 35 to 2000 pF only.

SECTION II EQUIPMENT REQUIREMENTS

4. Equipment Required. Table 2 identifies the specific equipment to be used in this calibration procedure. This equipment is issued with Secondary Transfer Calibration Standards Set AN/GSM-286. Alternate items may be used by the calibrating activity when the equipment listed in table 2 is not available. The items selected must be verified to perform satisfactorily prior to use and must bear evidence of current calibration. The equipment must meet or exceed the minimum use specifications listed in table 2.

5. Accessories Required. The accessories required for this calibration are common usage accessories, issued as indicated in paragraph 4 above, and are not listed in this calibration procedure.

Table 2. Minimum Specifications of Equipment Required

Common name	Minimum use specifications	Manufacturer and model (part number)
CAPACITANCE STANDARD	Range: 2000 and 5000 Pf Accuracy: +0.1%	Arco, Model SS32 (7907233)
PRECISION COMPONENT ANALYZER	Capacitance- Range: 0.1 pF to 2000 µf Accuracy: ± 0.05 %	Wayne-Kerr, Model 6425B
RESISTANCE STANDARD (NO.1)	Range: 0.01Ω to 1,111,111Ω Accuracy: ±0.03% of indication	Biddle-Gray Model 71-631 (7910328)
RESISTANCE STANDARD (NO.2)	Range: 100 KΩ to 10 MΩ Accuracy: ±0.02%	ICC, Model CR10M (8598965)
RESISTANCE STANDARD (NO.3)	Range: 10 to 100 MΩ Accuracy: ±0.05%	ICC, Model CR100M (8598966)
RESISTANCE STANDARD (NO.4)	Range: 1 to 1000 MΩ Accuracy: ±1%	ICC Model CR1000M (6579478)
RESISTANCE STANDARD (NO.5)	Range: 10,000 MΩ Accuracy: ±3.5%	Penn-Airborne, Model 9A-5120-103 (MIS-10412-4)
VARIABLE CAPACITOR	Range: 40 to 1000 pF Accuracy: +0.1% ¹	General Radio, Model 1422D (8579475)

¹100 to 1000 pF range: +0.6 pF.

**SECTION III
CALIBRATION PROCESS FOR SIMMONS PRECISION, INC.
MODEL 472090-002**

6. Preliminary Instructions

a. The instructions outlined in paragraphs 6 and 7 are preparatory to the calibration process. Personnel should become familiar with the entire bulletin before beginning the calibration.

b. Items of equipment used in this procedure are referenced within the text by common name as listed in table 2.

c. Unless otherwise specified, verify the result of each test and, whenever the test requirement is not met, take corrective action before continuing with the calibration. Adjustments required to calibrate the TI are included in this procedure. Additional maintenance information is contained in the manufacturers' manuals for this TI.

d. Unless otherwise specified all controls and control settings refer to the TI.

7. Equipment Setup

WARNING

HIGH VOLTAGE is used or exposed during the performance of this calibration. DEATH ON CONTACT may result if personnel fail to observe safety precautions. REDUCE OUTPUT(S) to minimum after each step within the performance check where applicable.

CAUTION

This TI shall be powered by 115 V ac, 400 Hz only. Connection to 115 V ac, 60 Hz will damage the TI.

- a. Open the TI and remove accessory cover.
- b. Set **MODE SELECT** switch to **OFF** position.
- c. Connect power cable to TI at receptacle marked **CAUTION: CONNECT TEST SET TO 115 V 400 HZ POWER ONLY**.
- d. Connect adapter cable [SP 10008521 (p/o TD)] to power cable.

CAUTION

Verify that 400 Hz power source is turned off.

- e. Connect three leads of adapter cable (p/o TI) to 400 Hz power source as listed in (1) through (3) below:
 - (1) Black - high side of output.
 - (2) White - low side of output.
 - (3) Green - ground on power source.
- f. Set TI **MODE SELECT** switch to **MEAS EXT** position. Turn on 400 Hz power source. Allow a 5-minute warm-up period.

8. Internal Calibration

a. Performance Check

- (1) Set switches as listed in (a) and b below:
 - (a) **T/U COMP** to **T/U** position.
 - (b) **RANGE** to **LO** position.
- (2) Open the **CALIBRATION ADJUSTMENT** cover (fig. 1) and set all switches to **OUT** position.

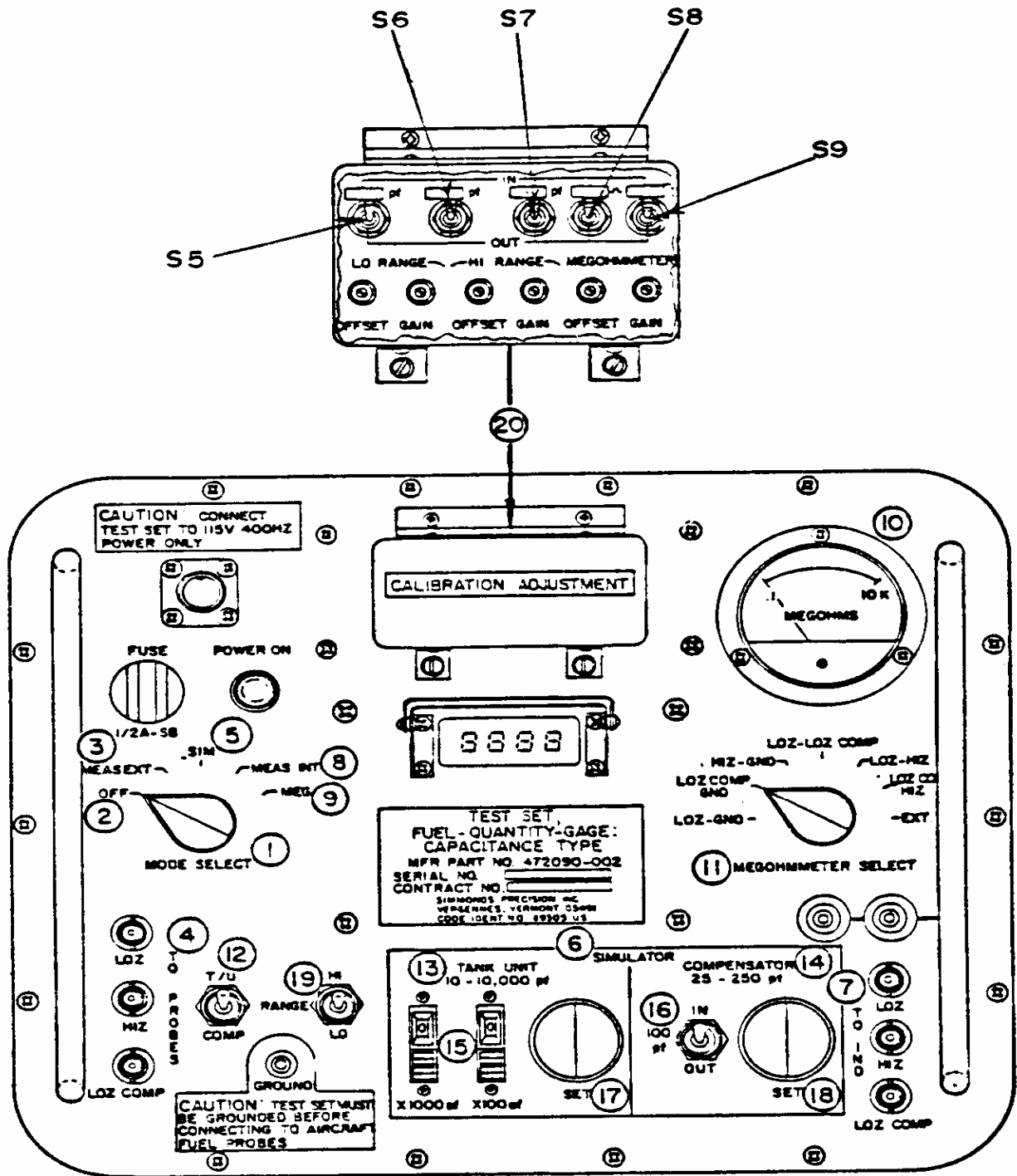

Figure 1. Simmons Precision, Inc. Model 472090-002, controls and adjustments locations.

- (3) Set S5 (left most toggle switch, fig.1) to the **IN** position.
- (4) If digital display does not indicate value stamped above S5 (fig.1), perform **b** (1) below.
- (5) Set switches as listed in (a) through (c) below (fig. 1).
 - (a) S5 to **OUT** position.
 - (b) S6 to **IN** position. If digital display does not indicate value stamped above S6 perform **b** (2) below.
 - (c) S6 to **OUT** position.
- (6) Repeat (3) through (5) (c) until both display values are equal to value stamped above each switch and no further adjustments are required.
- (7) Set switches as listed in (a) through (g) below (fig 1):
 - (a) **RANGE** to **HI** position.
 - (b) S6 to **IN** position. If display does not indicate value stamped above S6, perform **b** (3) below.
 - (c) S6 to **OUT** position and S7 to **IN** position. If display does not indicate value stamped above S7 , perform **b** (4) below.
 - (d) S7 to **OUT** position.
 - (e) **MODE SELECT** to **MEG** position and **MEGOHMMETER SELECT** to **EXT** position.
 - (f) S8 to **IN** position. If **MEGOHMS** meter does not read value stamped above S8 , perform **b** (5) below.
 - (g) S8 to **OUT** and S9 (farthest right toggle switch fig.1) to **IN** positions.
- (8) If **MEGOHMS** meter does not read value stamped above S9 (fig 1), perform **b** (6) below.
- (9) Set S9 switch (fig.1) to **OUT** position.

b. Adjustments

- (1) Adjust **LO RANGE OFFSET** trimmer screw (fig. 1) until display reads same as value stamped above S5 switch (fig.1) (R).
- (2) Adjust **LO RANGE GAIN** trimmer screw until display reads same as value stamped above S6 switch (fig.1) (R).
- (3) Adjust **HI RANGE OFFSET** trimmer screw until display reads same as value stamped above S6 switch (fig.1) (R).

TB 9-4920-451-35

(4) Adjust **HI RANGE GAIN** trimmer screw until display reads same as value stamped above S7 switch (fig.1). If necessary repeat (3) above until no further adjustments are required (R).

(5) Adjust **MEGOHMMETER OFFSET** trimmer screw until **MEGOHMS** meter reads same value as stamped above S8 switch (fig.1) (R).

(6) Adjust **MEGOHMMETER GAIN** trimmer screw until **MEGOHMS** meter reads same value as stamped above S9 switch (fig.1). If necessary repeat (5) above until no further adjustments are required (R).

9. Capacitance Measurement Calibration

a. Performance Check

(1) Set **MODE SELECT** switch to **MEAS EXT** position.

(2) Set **RANGE** switch to **LO** position.

(3) Connect shorting plug (p/o TI) to **TO PROBES LOZ COMP** (fig 1).

(4) Connect variable capacitor to TI, G to **TO PROBES LOZ** and 115 to **TO PROBES HIZ**.

(5) Adjust variable capacitor to 40 pF. TI display will indicate between 39.8 and 40.2 pF.

(6) Repeat technique of (5) above for settings and indications listed in table 4.

b. Adjustments. No adjustments can be made.

Table 4. Capacitance

Capacitance standard settings (pF)	Test instrument indications (pF)	
	Min	Max
60	59.7	60.3
80	79.6	80.4
100	99.5	100.5
180	179.1	180.9
300	298.5	301.5
400	398	402
600	597	603
800	796	804
1000 ¹	995	1005
2000 ^{1 2}	1990	2010

¹Set **RANGE** switch to **HI** for 1000 and 2000 pF

²Connect capacitance standard .002 G to HIZ and remaining banana jack to **LOZ** for 2000 pF.

10. Capacitance Substitution Calibration

a. Performance Check

- (1) Configure the precision component analyzer to measure capacitance and connect to **TO IND LOZ** and **TO IND HIZ** on TI.
- (2) Connect shorting plug (p/o TI) to **TO IND LOZ COMP**.
- (3) Energize precision component analyzer and allow sufficient warm-up time.
- (4) Set **MODE SELECT** switch to **MEAS INT** position.
- (5) Set **T/U COMP** switch to **T/U** and **RANGE** switch to **LO** position.
- (6) Set **TANK UNIT SIMULATOR X1000 pF** and **X100 pF** switches to **0**.
- (7) Adjust **TANK UNIT SIMULATOR SET** control for a 40-pF reading on digital display (push down on control for coarse tuning and let up for fine tuning).

NOTE

To attain readings greater than 100 pf on digital display the **SIMULATOR TANK UNIT X100 pf** may have to be in a position other than 0.

- (8) Set **MODE SELECT** switch to **SIM** position. Precision component analyzer will indicate between 39.8 and 40.2 pF.
- (9) Repeat (4), (7) and (8) above for settings and indications up to 800 pF as shown in table 5.
- (10) Set **RANGE** switch to **HI** position and **SIMULATOR TANK UNIT X100 pF** switch to **9**.
- (11) Adjust **SIMULATOR TANK UNIT SET** control for a 1000 pF indication on TI display. Precision component analyzer will indicate between 995.0 and 1005 pF.
- (12) Set **X1000 pF** switch to **1** and adjust **SIMULATOR TANK UNIT SET** control for a 2000 pF indication on TI display. Precision component analyzer will indicate between 1990.0 and 2010.0 pF.
- (13) Set controls as listed in (a) through (c) below:
 - (a) **T/U COMP** switch to **COMP**.
 - (b) **RANGE** switch to **LO**.
 - (c) **SIMULATOR COMPENSATOR 100 pF** control to **OUT**.

TB 9-4920-451-35

- (14) Remove cable from **TO IND LOZ** and shorting plug from **TO IND LOZ COMP**.
- (15) Connect shorting plug (p/o TI) to **TO IND LOZ** and cable to **TO IND LOZ COMP**.
- (16) Position controls as listed in (a) through (c) below:
 - (a) **MODE SELECT** switch to **MEAS INT**.
 - (b) **SIMULATOR COMPENSATOR SET** control for 40 pF on digital display.
 - (c) **MODE SELECT** switch to **SIM**.
- (17) Precision component analyzer will indicate between 39.8 and 40.2 pF.
- (18) Repeat (16) and (17) for each value through 100 pF as shown in table 5.

Table 5. Capacitance Substitution

Test instrument indications	Precision component analyzer indications (pF)	
	Min	Max
60	59.7	60.3
80	79.6	80.4
100	99.5	100.5
180	179.1	180.9
300	298.5	301.5
400	398.0	402.0
600	597.0	603.0
800	796.0	804.0

- (19) Set **SIMULATOR COMPENSATOR 100 pF** switch to **IN**.
 - (20) Repeat (16) and (17) for 180 pF value.
- 11. Resistance Measurement Calibration**
- a. Performance Check**
- (1) Set switches as listed in (a) through (c) below:
 - (a) **MODE SELECT** to **MEG**.
 - (b) **MEGOHMMETER SELECT** to **EXT**.
 - (c) S8 switch (fig. 1) to **IN**.
 - (2) If **MEGOHMS** meter does not indicate value stamped above S8 switch (fig. 1), perform **b(1)** below.
 - (3) Set S8 switch (fig. 1) to **OUT** position and S9 switch (fig. 1) to **IN**.
 - (4) If **MEGOHMS** meter does not indicate value stamped above S9 switch (fig. 1), perform **b(2)** below.

- (5) Set S9 switch (fig.1) to **OUT** position.
- (6) Set **MEGOHMMETER SELECT** switch to **LOZ GND**.
- (7) Connect appropriate resistance standard (NO. 1 through NO. 5) to **TO PROBES** terminals, as shown in table 6.
- (8) Measure each resistance standard listed in table 6. **MEGOHMS** meter will indicate within limits specified.

Table 6. Resistance

MEGOHMMETER SELECT switch positions	Connection TO PROBES terminals	Resistance standard value (MΩ)	Actual value +1 div
LOZ GND	LOZ TO RESISTOR TO GND	1.0 10 100 1 000	-4 div
LOZ COMP GND	LOZ COMP TO RESISTOR TO GROUND	1.0 10 100 1000	---
HIZ GND	HIZ TO RESISTOR TO GROUND	1.0 10 100 1000	---
LOZ-LOZ COMP	LOZ TO RESISTOR TO LOZ COMP	1.0 10 100 1000	---
LOZ-HIZ	LOZ TO RESISTOR TO HIZ HIZ	1.0 10 100 1000	---
LOZ COMP-HIZ	LOZ COMP TO RESISTOR TO HIZ	1.0 10 100 1000	---
EXT	ACROSS EXTERNAL RESISTANCE TERMINALS	1.0 10 100 1000	---

TB 9-4920-451-35

b. Adjustments

(1) Set **MEGOHMMETER OFFSET** trimmer screw (fig. 1) for meter indication that is the same value as stamped above S8 switch (fig.1) (R).

(2) Set **MEGOHMMETER GAIN** (fig. 1) until meter agrees with value stamped above switch S9 (fig.1) (R).

12. Final Procedure

- a. Deenergize and disconnect all equipment.
- b. Annotate and affix DA label/form in accordance with TB 750-25.

SECTION IV CALIBRATION PROCESS FOR GULL AIRBORNE INSTRUMENTS, MODEL GTF-4

13. Preliminary Instructions

a. The instructions outlined in paragraphs **13** and **14** are preparatory to the calibration process. Personnel should become familiar with the entire bulletin before beginning the calibration.

b. Items of equipment used in this procedure are referenced within the text by common name as listed in table 2.

c. Unless otherwise specified, verify the result of each test and, whenever the test requirement is not met, take corrective action before continuing with the calibration. Adjustments required to calibrate the TI are included in this procedure. Additional maintenance information is contained in the manufacturers' manuals for this TI.

d. Unless otherwise specified, all controls and control settings refer to the TI.

14. Equipment Setup

WARNING

HIGH VOLTAGE is used or exposed during the performance of this calibration. DEATH ON CONTACT may result if personnel fail to observe safety precautions. REDUCE OUTPUT(S) to precautions. REDUCE OUTPUT(S) to minimum after each step within the performance check where applicable.

- a. Remove top protective cover as required for adjustments.
- b. Connect TI to 115 V, 400 Hz, using cables supplied with TI.
- c. Set **POWER ON/OFF** switch to **ON** and allow at least 30 minutes for warm-up and stabilization.

15. Capacitance

a. Performance Check

- (1) Set switches as listed in (a) through (c) below:
 - (a) **DISPLAY SELECT** switch to **CAP (pF)**.
 - (b) **CAPACITANCE FUNCTION** switch to **A/C TEST COMP**.
 - (c) **CAPACITANCE RANGE (pF)** switch to **HIGH ADJ**.
- (2) If digital indicator does not indicate high value stamped on **CAP STANDARDS** placard on front panel, adjust **CAP STANDARD HIGH ADJ** control (front panel).
- (3) Set **CAPACITANCE RANGE (pF)** switch to **LOW ADJ**. If digital indicator does not indicate the low value stamped on **CAP STANDARDS** placard on front panel, adjust **CAP STANDARD LOW ADJ** control (front panel).
- (4) Repeat (2) and (3) above until no further adjustment is required.
- (5) Set **CAPACITANCE RANGE (pF)** switch to **8000, 4000, 1000, and 200** ranges respectively. If digital indicator does not zero on each range setting, perform **b** below.
- (6) Connect variable capacitor to **COAX A, COMP C** and **GND**. Measure lead capacitance and record.
- (7) Set **CAPACITANCE RANGE (pF)** switch to **200 pF**.
- (8) Set variable capacitor to 35 pF. If TI does not indicate between 34 and 36 pF plus lead capacitance recorded in (6) above, perform adjustments as listed in table 7.
- (9) Repeat technique of (8) above using settings and indications in table 7. If TI does not indicate within limits specified, perform adjustments listed in table 7.

Table 7. Capacitance Check

Test Instrument		Variable capacitor or standard capacitor		Adjustments (fig. 2)
RANGE settings (pF)	Indications	Min	Max	
200	100	99.0	101.0	R21
1000	500	495.0	505.0	R20
4000	1000	980.0	1020. 0	- - -
4000 ¹	3000	2980. 0	3020. 0	R19
8000	5000	4960. 0	5040. 0	- - -
8000	7000	6960. 0	7040. 0	- - -

¹Substitute capacitance standard for variable capacitor.

TB 9-4920-451-35

b. Adjustments. Adjust R85 (fig. 2) on 200 pF range and R86 on 1000 pF range for a zero indication then repeat (2) through (4) above.

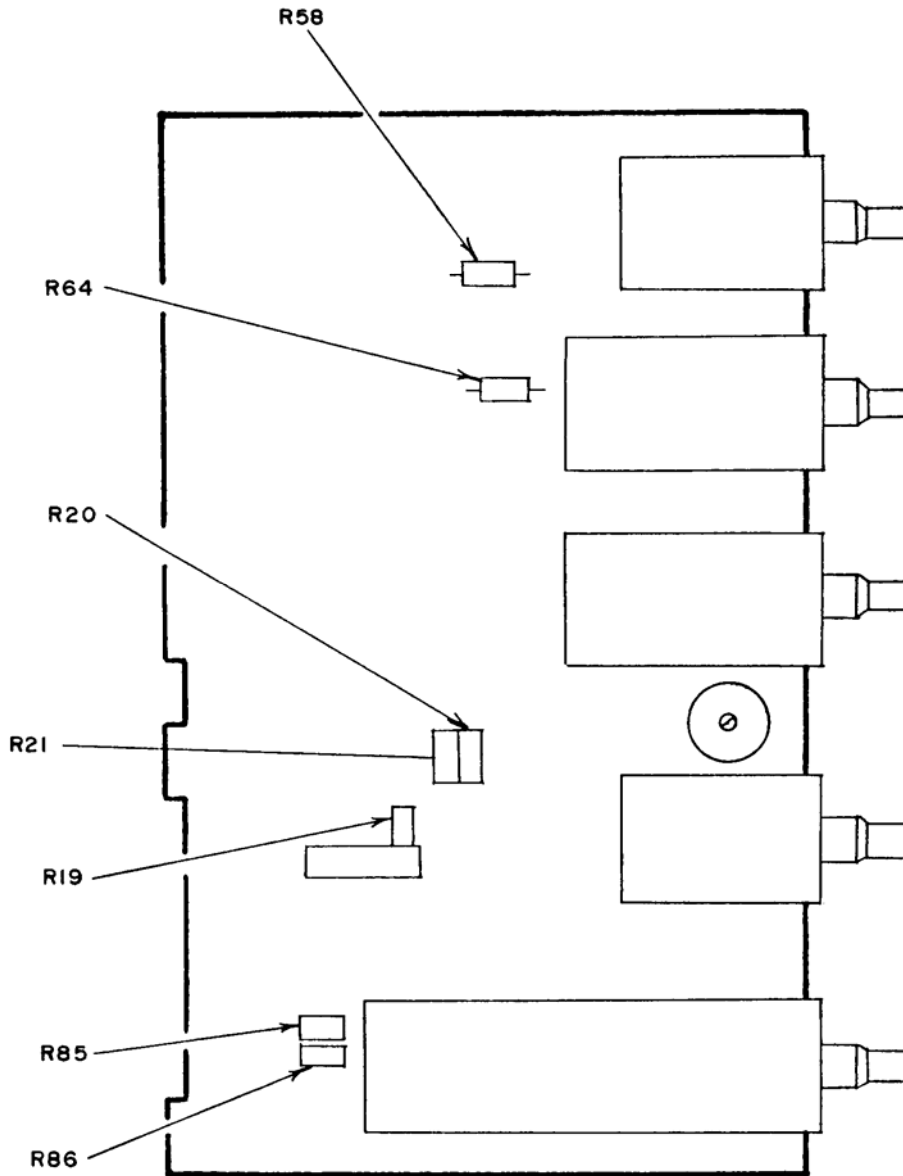

Figure 2. Gull Airborne Instruments, Model GTF-4 – adjustment locations

16. Resistance

a. Performance Check

- (1) Connect **TI EXT RES** terminals to resistance standard (NO.1).
- (2) Set switches as listed in (a) through (c) below:
 - (a) **DISPLAY SELECT** switch to **RES (MEG)**.
 - (b) **RESISTANCE FUNCTION** switch to **EXT RES**.
 - (c) **RESISTANCE RANGE (MEG)** switch to **0.1-1**.
- (3) Set resistance standard to .1000 MΩ. If TI does not indicate between .0900 and .1100 MΩ, perform **b(1)** and (2) below.
- (4) Set **RESISTANCE RANGE (MEG)** switch to **LOW TEST**. Digital indicator will indicate .0900 to .1100 MΩ.
- (5) Set **RESISTANCE RANGE (MEG)** switch to **0.1-1**.
- (6) Set resistance standard NO. 1 to .9500 MΩ. If digital indicator does not indicate between .9400 and .9600 MΩ, perform **b (2)** below.
- (7) Set **RESISTANCE RANGE (MEG)** switch to **HIGH TEST**. Digital indicator will indicate between **.9400 and .9600 MΩ**.
- (8) Set **RESISTANCE RANGE (MEG)** switch to **0.1-1** position.
- (9) Set resistance standard NO. 1 to .1. If digital indicator does not indicate within +.01 MΩ, repeat **b(1)** and (2) above for optimum reading.
- (10) Repeat (9) above for resistance settings of **.2, .3, .4, .5, .6, .7, .8, and .95 MΩ**.
- (11) Connect appropriate resistance standard NO. 2 through NO. 5 and set TI to settings listed in table 8.

Table 8. Resistance Check

Test instrument resistance (MEG) RANGE switch settings	Resistance standard indications		Test instrument indications (MΩ) ¹	
	Standard used	Resistance settings (MΩ)	Min	Max
1-10	NO. 2	5	4.75	5.25
		9	8.55	9.45
10-100	NO. 3	50	47.50	52.50
		90	85.50	94.50
100-1K	NO. 4	500	475.00	525.00
		900	855.00	945.00
1K-10K	NO. 4	1000	900.00	1100.00
	NO. 5	10,000	9000.00	11,000.00
10K-100K	NO. 5	10,000	8500.00	11,500.00

¹If TI indicates over range (indicator flashing) advance **RANGE** switch to next higher range.

TB 9-4920-451-35

b. Adjustments

- (1) Adjust R58 (fig. 2) for a reading of **.1000 MΩ** on digital indication.
- (2) Adjust R64 (fig. 2) for a reading of **.9500 MΩ**.

17. Final Procedure

- a. Deenergize and disconnect all equipment.
- b. Annotate and affix DA label/form in accordance with TB 750-25.

**SECTION V
CALIBRATION PROCESS FOR CONSOLIDATED AIRBORNE SYSTEMS, MODEL
TF20-1 AND TF579**

18. Preliminary Instructions

- a. The instructions outlined in paragraphs **18** and **19** are preparatory to the calibration process. Personnel should become familiar with the entire bulletin before beginning the calibration.
- b. Items of equipment used in this procedure are referenced within the text by common name as listed in table 2.
- c. Unless otherwise specified, verify the result of each test and, whenever the test requirement is not met, take corrective action before continuing with the calibration. Adjustments required to calibrate the TI are included in this procedure. Additional maintenance information is contained in the manufacturer's manual for this TI.
- d. Unless otherwise specified, all controls and control settings refer to the TI.

19. Equipment Setup

WARNING

HIGH VOLTAGE is used or exposed during the performance of this calibration. DEATH ON CONTACT may result if personnel fail to observe safety precautions. REDUCE OUTPUT(S) to minimum after each step within the performance check where applicable.

- a. Remove top protective cover as required for adjustments.
- b. Connect autotransformer to 115 V, 400 Hz source and adjust for 115 V.
- c. Connect TI to autotransformer using cables supplied with TI.
- d. Set **POWER ON/OFF** switch to on and allow at least 30 minutes for warm-up and stabilization.

- e. Set switches as listed in (1) through (3) below:
 - (1) **FUNCTION SELECTOR** to **CAP IND-ZERO CAL.**
 - (2) **CAP RES CHECK** to **CAP.**
 - (3) **CAPACITANCE INDICATOR-RANGE SELECTOR** to **X1.**
- f. Set **CAPACITANCE INDICATOR ZERO ADJUST** control for a zero indication on meter.
- g. Set **CAPACITANCE INDICATOR-RANGE SELECTOR** switch back and forth through its four ranges. If meter does not indicate zero, adjust R120 (fig. 3) for minimum shift of pointer.
- h. Repeat e above for **RANGE SELECTOR** switch settings **X10** and **X50**. If meter does not indicate zero on all ranges, repeat e and f above for optimum zero.

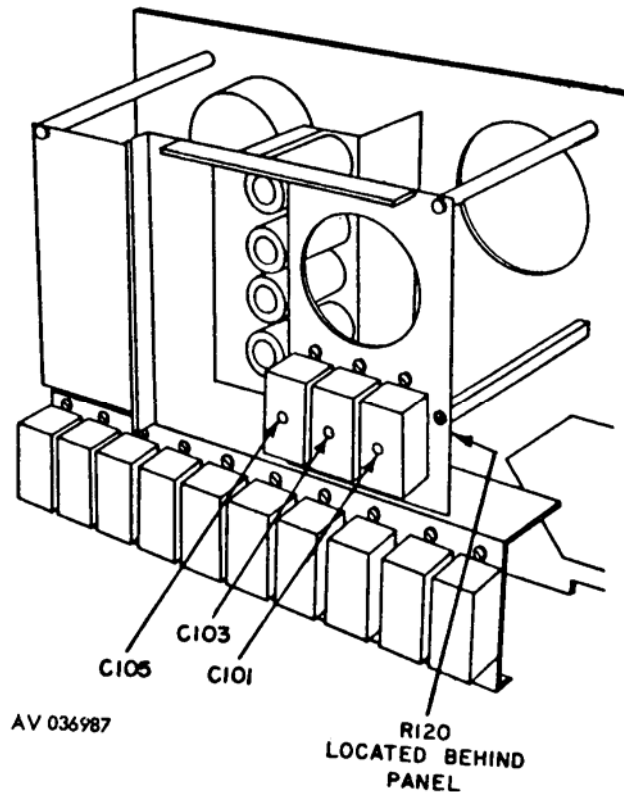

Figure 3. Consolidated Airborne Systems, Models TF20-1 and TF579 - adjustment locations.

- i. Set **CAPACITANCE INDICATOR-RANGE SELECTOR** switch to appropriate range for value stamped on front of TI, and set function switch to **CAP-IND-HIGH CAL.** If capacitance meter does not indicate value stamped on front panel, adjust **HIGH ADJUST** control.

TB 9-4920-451-35

j. Adjust autotransformer between 105 and 125 V. Capacitance meter will indicate within ± 5 percent of reading stamped on front panel.

20. Capacitance

a. Performance Check

(1) Connect variable capacitor, 1150 to tank unit **A** coax connector using shielded test probe (p/o TI).

(2) Connect variable capacitor GND terminal to **TI B-UNSH** terminal using unshielded test probe (p/o TI).

(3) Set variable capacitor for 100 pF.

(4) Set **FUNCTION SELECTOR** switch to **TANK UNIT TEST-UNSH** and set **RANGE SELECTOR** switch to **X1**. If capacitance indicator meter does not indicate between 99.50 and 100.50 pF, perform **b** below.

(5) Repeat (4) above using settings, indications, and adjustments listed in table 9.

Table 9. Capacitance

Variable capacitor (pF)	Test instrument			
	Range	Indications (pF)		Adjustments (fig. 3)
		Min	Max	
300	X3	99.50	100.5	C103
1000	X10	99.50	100.5	C105
1000	X50	19.50	20.50	---
5000 ¹	X50	99.5	100.5	---

¹Substitute capacitance standard.

b. Adjustments. Adjust C101 (fig. 3) for a capacitance indication of 100 pF.

21. Resistance

a. Performance Check

(1) Set **RANGE SELECT** switch to **ZERO CAL**. If megohmmeter does not indicate zero adjust **ZERO ADJ** (front panel) for zero indication.

(2) Set **CAP RES-CHECK** switch to **MEGOHMS AC** position and set **A-B MEGOHMMETER** and **RANGE SELECTOR** switch to **MIDSCALE CAL** position. If megohmmeter does not indicate midscale, adjust **MIDSCALE ADJ** (front panel) for midscale indication.

(3) Connect resistance standard (NO.1) to **TANK UNIT A** and **TANK UNIT B** using cables furnished with TI.

- (4) Set resistance standard NO. 1 for 500,000 Ω.
- (5) Set megohmmeter **RANGE SELECTOR** switch to **X1**.
- (6) Adjust resistance standard NO. 1 for an indication of .5 MΩ on megohmmeter. Resistance standard will indicate between 450,000 and 550,000 Ω.
- (7) Repeat technique of (5) and (6) above for settings and indications listed in table 10.

Table 10. Resistance

Test instrument		Resistance Standard indications (MΩ)	
RANGE switch settings	Megohmmeter indications (MΩ)	Min	Max
X1	.7	0.63	0.77
X1 ¹	1.5	1.35	1.65
X1	2	1.8	2.2
X1	5	4.5	5.5
X1	10	9.0	11.0
X10	10	90.0	110.0
X100	10	900.0	1100.0
X1000	1	900.0	1100.0

¹Substitute resistance standards (No.1 through No5) as required.

22. Final Procedure

- a. Deenergize and disconnect all equipment.
- b. Annotate and affix DA label/form in accordance with TB 750-25.

By Order of the Secretary of the Army:

Official:



JOEL B. HUDSON

*Administrative Assistant to the
Secretary of the Army*

0323701

PETER J. SCHOOMAKER

General, United States Army

Chief of Staff

Distribution:

To be distributed in accordance with IDN 342054, requirements for calibration procedure
TB 9-4920-451-35.

Instructions for Submitting an Electronic 2028

The following format must be used if submitting an electronic 2028. The subject line must be exactly the same and all fields must be included; however, only the following fields are mandatory: 1, 3, 4, 5, 6, 7, 8, 9, 10, 13, 15, 16, 17, and 27.

From: "Whomever" whomever@redstone.army.mil
To: <2028@redstone.army.mil

Subject: DA Form 2028

1. **From:** Joe Smith
2. **Unit:** home
3. **Address:** 4300 Park
4. **City:** Hometown
5. **St:** MO
6. **Zip:** 77777
7. **Date Sent:** 19-OCT-93
8. **Pub no:** 55-2840-229-23
9. **Pub Title:** TM
10. **Publication Date:** 04-JUL-85
11. **Change Number:** 7
12. **Submitter Rank:** MSG
13. **Submitter FName:** Joe
14. **Submitter MName:** T
15. **Submitter LName:** Smith
16. **Submitter Phone:** 123-123-1234
17. **Problem:** 1
18. **Page:** 2
19. **Paragraph:** 3
20. **Line:** 4
21. **NSN:** 5
22. **Reference:** 6
23. **Figure:** 7
24. **Table:** 8
25. **Item:** 9
26. **Total:** 123
27. **Text**

This is the text for the problem below line 27.

